



**CENTRO DE
TECNO-SOLUCIONES
E INNOVACIÓN**

MAQUINARIA PARA PROCESO DE ALIMENTOS





**EN MIMTECH
SOMOS ESPECIALISTAS EN
MAQUINARIA PARA
LA INDUSTRIA ALIMENTARIA
CON MAS DE 40 AÑOS
DE EXPERIENCIA**

Nos especializamos en proyectos a medida; diseñemos, fabricamos e integramos soluciones innovadoras con el respaldo de nuestra experiencia. Acompañamos y asesoramos a nuestros clientes en la operación. Además contamos con excelente servicio post-venta.

+16MIL
EQUIPOS INSTALADOS

+40
AÑOS DE EXPERIENCIA

+10
PAISES EN TODO EL MUNDO

+110
COLABORADORES PROFESIONALES

EXPERTOS EN MAQUINARIA DE PROCESO DE ALIMENTOS



ASESORÍA PARA PROYECTOS LLAVE EN MANO





SOLUCIONES INTEGRALES DE MÁXIMA PRODUCTIVIDAD EN EL PROCESO DE ALIMENTOS

Lavado

Clasificación y selección de frutas

Sanitizado

Rebanado y cubicado

Despulpado

Mezclado

Llenado y envasado

Tratamiento de alta presión

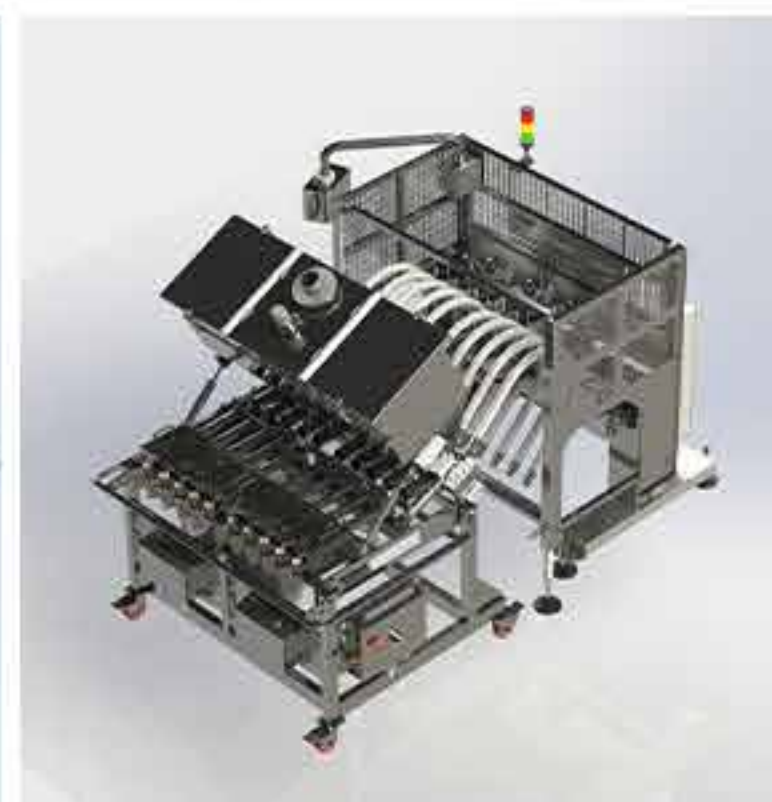
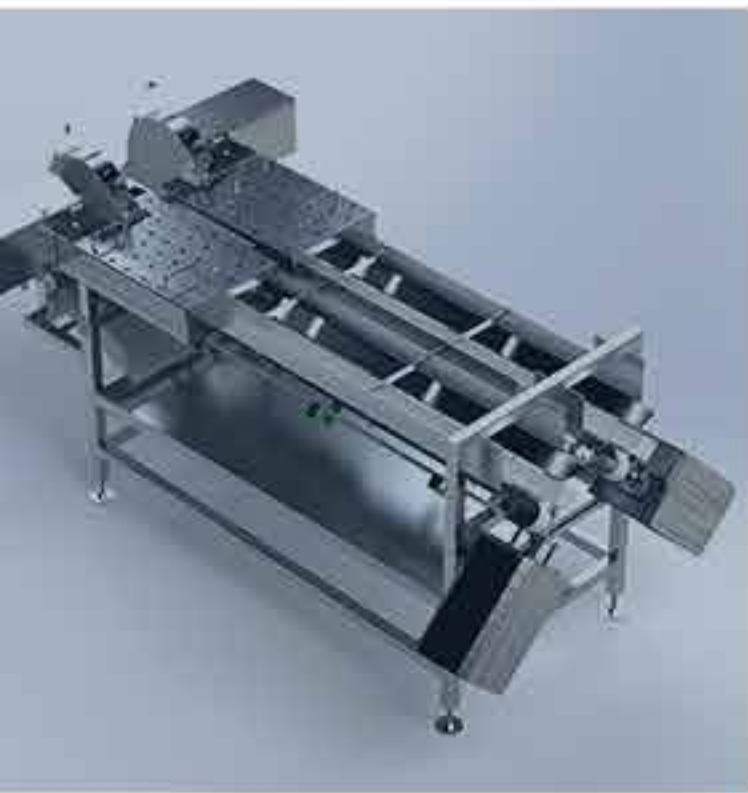
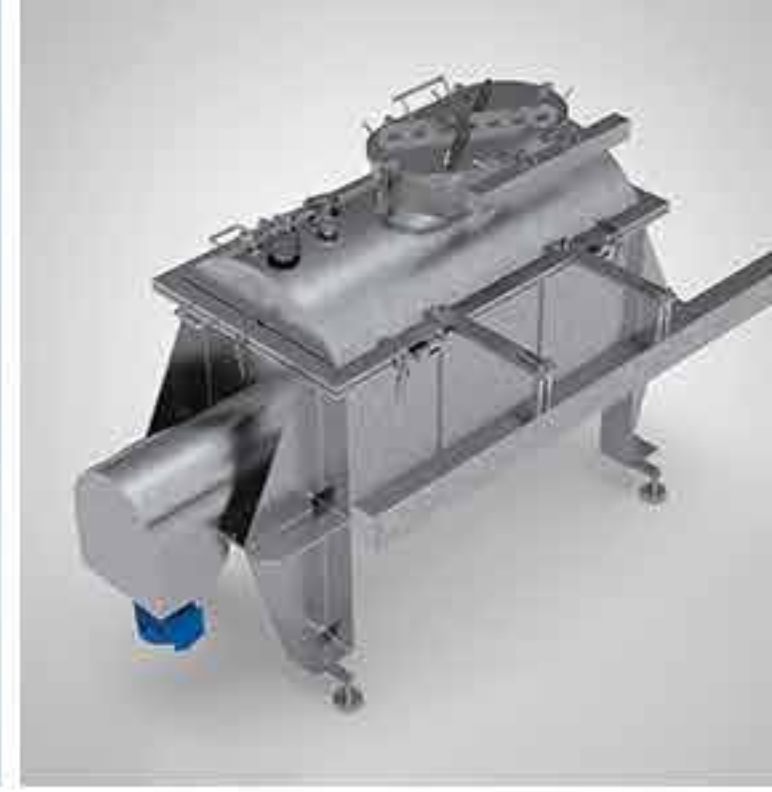

NUESTROS CLIENTES



MIMTECH[®]

Tecno-soluciones e innovación para la industria alimentaria

Carr. Estatal No. 431 Km 1.933, Bodega 2B, Europark II,
El Marqués, CP. 76246, Querétaro, México. T. +52 442 251 70 52
www.mimtech.mx

-
contacto@mimtech.mx

